

GRID TIE INVERTER



MANUAL GRID TIE INVERTER EXTENTION-KIT

**EXTENSION-KIT FOR SMALL URBAN
WIND TURBINES AND SOLAR PANELS
EXTENTION-KIT TYPE: UWT-I-250 XT-KIT**

SWEA EUROPE

**FRIENDLY CARE FOR YOUR EXPENSES
AND OUR ENVIRONMENT!**

WWW.SWEA.NL

THE NETHERLANDS

SWEA SOLAR & WIND ENERGY APPLICATIONS

250 WATT GRID TIE INVERTER FOR EXTENSION ON THE UWT-I-250 W STARTER-KIT AND TO UN AS A GRID TIE INVERTER FOR SOLAR PANELS.

DEAR CUSTOMERS

May we take this opportunity to thank you for purchasing this Grid Tie Inverter extension kit (GTIXK). We strongly recommend that you carefully study the operating instructions before attempting to operate the unit and you note the listed precautions.

SAFETY INFORMATION:

This unit should only be used in accordance with the power line specification as marked on the inverter and AP-box. AC 120 V or 240 V, 60 or 50 Hz. The DC input of the AP-box should never exceed 52 V Above 52 V DC the Dumpload will be switched on. The DC-input of the inverter is adjusted at 54 V DC. In this way the AP-box will be switched earlier than the inverter and gives protection to the connected inverter or inverters. When the Dumpload is switched on he slows down the speed of the windturbine. During this period the inverters are functioning normally till the Dumpload is shutdown the windturbine below 17 V DC. At 17 V DC the speed of the windturbine is low enough to switch off the Dumpload. Make sure that you take care of safety measures as described in the manual of your own windturbine. Your dealer can advice about several combinations that will perform well. For other windturbines you should make sure that all safety requirements are made before connecting the windturbine to the installed star-terkit. The maximum power of the windturbine should comply with the configuration as explained in the manual. If in doubt, always ask your dealer.

CAUTION:

When this GTI is plugged into the Wall outlet, do not place your eyes close to the openings to look into the inside if this GTI of AP-box. Do not open covers or attempt to repair this product by yourself. Always refer servicing to qualified personnel.

WARNING:

To reduce the risk of fire or electric shock, do not expose the equipment to rain or moisture. To reduce the risk of fire, electric shock, use the recommended accessories only.

This product incorporates copyright protected technology that is protected by method claims of intellectual property rights owned by SWEA EUROPE. Use of this copyright protected technology must be authorized by SWEA EUROPE and is intended for home use only unless otherwise authorized by Swea Europe. Reverse engineering or disassembly is prohibited. Manufactured under licence from SWEA EUROPE and the SWEA symbol are trademarks from SWEA EUROPE. All rights reserved.



PRECAUTIONS:

Please read this precautions before operating this unit.

POWER CORD PROTECTION

To avoid malfunction of this product against electric shock, fire or personal injury, please observe the following.

- 0 Hold the plug firmly when connecting or disconnecting the AC power supply to this unit.
- 0 Do not connect or disconnect the AC power when your hands are wet.
- 0 Keep the AC power cord away from heating appliances.
- 0 Never put heavy object on the power cord.
- 0 Do not attempt to repair or reconstruct the power cord in any way.

PLACEMENT

Avoid placing the unit in areas of:

- 0 Direct sunlight
 - 0 High temperature (over 35 Deg. Cel.) or high humidity (over 90%)
 - 0 High level of dust
- The internal parts may be damaged as a result.

FOREIGN OBJECTS

- 0 Touching internal parts of this unit is dangerous and may damage the GTI. Never attempt to disassembly the unit.
- 0 Do not put any foreign object into the units.

KEEP AWAY FROM WATER / MAGNETIC FIELDS

- 0 Keep the units away from flower vases, tubs, sinks, etc. If liquids are spilled into the units, serious damage will occur.
- 0 Do not place magnetic objects (such as speakers or permanent magnetic material) close to the unit.

IMPORTANT:

Before you switch on the equipment, please refer to the installation manual below.

WALL MOUNTING

- 0 Place the unit in vertical position to the wall. Inverter: fan must be located below. All units should be placed to the wall with a minimum distance of 10 cm at all sides.
- 0 Do NOT place the unit close or above heating devices.
- 0 The unit may be used in-house only. They are NOT water resistant.

CONDENSATION

Moister may form on the units in the following conditions:

- 0 Immediately after a heart has be turned on.
- 0 In a steamy or very humid room.
- 0 When the units are moved from a cold environment to a warm one. If moister formed inside this units, it may not operate properly. In this case, turn the power off and wait about one hour for the moister to evaporate.

Installation diagramme Starter-kit with 3 pcs. Extension-kits. Windturbine 250-500-750-1000 Watt

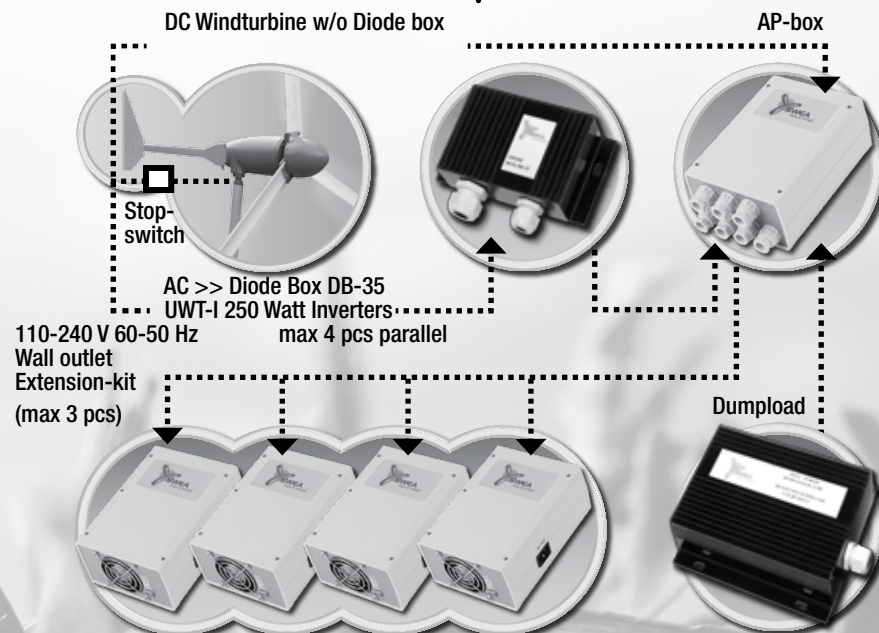

GETTING STARTED:

1. Table of contents
2. Features
3. Connection to the Grid and Windturbine
4. Install the extension kit to the wall
5. Maintenance
6. Product specifications

1. TABLE OF CONTENTS:

In the UWT-I-Starter-Kit is included:
 1x UWT-I-250 Grid Tie inverter 250 Watt 110-240V AC 60-50 Hz. (Delivery is 110V-60Hz or 240V-50Hz depending of your country)
 CPU Green is default installed into the unit (Optional max 3 x UWT-I-250 Extension kit can be installed on a UWT-I-250 starter kit)
 1x power cable. Suitable in your country
 1x set mounting material
 1x Manual

2. FEATURES: GRID TIE INVERTER UWT-I-250 EXTENSION KIT

2.1 GRID TIE INVERTER UWT-I-250 WATT

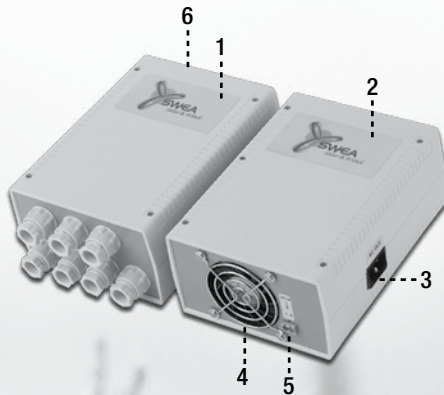

- 1: AP-box (not included see Starter-kit)
- 2: Grid Tie Inverter UWT-I-250 Watt.
- 3: Power out 110-240 V AC to the Grid 60-50 Hz (wall outlet)
Standard 110-240 V power cord is included
- 4: Fan
- 5: DC power in
- 6: Stop-switch

This Grid tie inverter is an extension to the UWT-I-250 STARTER KIT. Maximum 3 extension kits can be connected to one UWT-I-250-STARTER KIT. So you can extend from 250 Watt up to 1000 Watt to the grid. Only windturbines can be used who has a power out of 24-48 V DC.

Also you can use this Inverter extension kit as a stand alone inverter for Solar panels. Recommended solar panels are 2x 130 Watt/ 84 cell 0,56 V per cell switched: parallel.

2.2 USE OF CPU

Default installed into the UWT-I-250 Grid Tie inverter is the Green CPU. This CPU can be used together with windturbines who has power out up to max. 48 V. Optional can be installed the RED type CPU. This CPU has to be installed when the power out of the windturbine is 24-36 V. For solarpanels you have to install the CPU type: SOL. Ask your dealer for this RED and SOL CPU.

2.3 CPU-CURVES DC-IN TO THE GENERATED POWER TO THE GRID

See below the curves for this 2 colour CPU's.

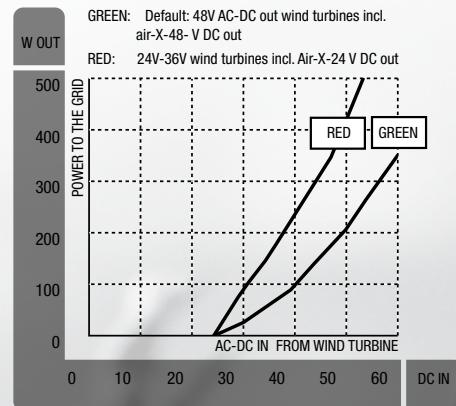

Specs Curves Default CPU
 GREEN: Start 27,2 V
 200 W 49 V
 For windturbine
 300 W-48 V FD 2.5-300
 1 kw-48 V FD 1 kw
 SOL CPU: start 0 W-30 V, 200 W-38 V

2.4 HOW TO CHANGE CPU

Take care before starting up the system that you have installed the correct CPU for the windturbine you are using to get the best results to the grid.

Topside inverter without upper part of the housing.

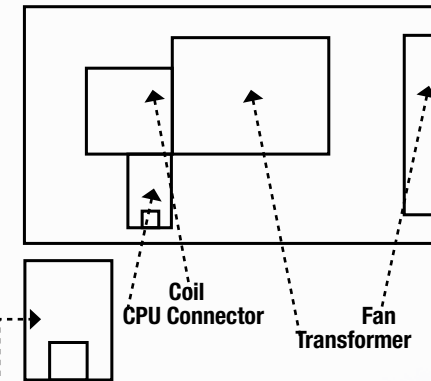

CPU STARTER KIT

Take out first, with a small screwdriver, the CPU. Put the screwdriver between CPU and connector and push the CPU upwards.

CPU

Put the CPU in proper position!!! Look at the notch on the top site. It must be in this position placed into the inverter.

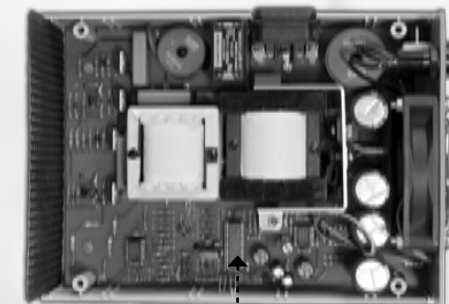

CPU that you can change.

3.0 CONNECTION TO THE GRID, WINDTURBINES AND SOLAR PANELS

3.1 TO INSTALL THIS UWT-I-250 XT-KIT AS AN EXTENSION KIT ON THE UWT-I-STARTER-KIT

Maximum 3 pcs Extension kits can be connected to the AP-box of the starter-kit. The Starter kit has one inverter of 250 Watt, + 3 extension kits of 250 Watt, makes together total 1000 Watt to the grid. When you install total 4 pcs inverters you can connect a 1000 Watt windturbine to the grid.

3.2 TO INSTALL THIS UWT-I-250 EXTENSION KIT AS A GRID TIE INVERTER FOR SOLAR PANELS

With special software, CPU "SOL" you may install maximum 2 peaces solar panels of 130 Watt connected parallel. Each panel must have 84 cells/ 0,56 Volt per cel. Ask your dealer for the solar panels and the SOL CPU.

STEP 4: INSTALL THE EXTENSION KIT TO THE WALL

Install the UWT-I-250 to the wall.

Step 1: Install the 4 pcs. iron plates to the bottom screws as follows:

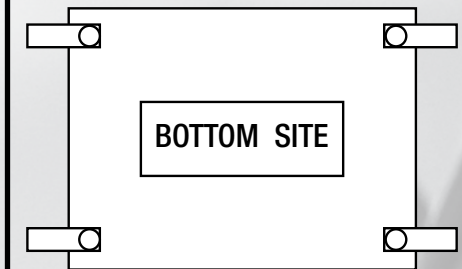

Step 2. Make 4 holes in the wall and use the plugs and screws to fasten the UWT-I-250 inverter to the wall. The fan must be located to the bottom

site. Put the DC power cable that comes from the AP-box with the connector that's fits into the connector DC-In of the inverter. Look at the correct site of the + and – of the cable-end. On the inverter is the + and the – labelled.

Step 3. Install then 110/240 Volt power cable into the inverter and the other site in the 110-240V 60-50Hz wall plug.

Start-up system.

When the windturbine, Diode box and AP-box are installed the inverter starts automatically to operate when the stopswitch is in the "normal operation" position and the windturbine is turning with enough speed.

5. MAINTENANCE

5.1. When you have to do maintenance to the system, switch on always the stop switch from the Ap-box and pull out the 220-110 Volt grid power cables. Do it only when there is no wind and the wind turbine is not turning. You can always use the stop-switch when the wind speed becomes to high and in dangerous situations.

5.2. BRAKE THE Windturbine.

When you have to take off the inverter or AP-box or Diode-box out of the installation than it is necessary for your safety to brake the windturbine. Switch on the stop-switch and the wind turbine will stop slowly. Take of the cable from the AP-box connector 4 and connect the disconnected wires. Do this immediately otherwise the wind turbine will start turning again. This is not applicable when you use only solar panels.

6. PRODUCT SPECIFICATIONS

Type:	UWT-I-250				
Output to the grid max:	200 watt	Efficiency	> 84% (between 10 -100% output)		
Power consumption	+/- 0,2 W (when windturbine is not turning)				
DC - in	Up to 24-52 V				
DC - in max	54V	DC-in>54V	Input Shorted		
Operating temperature	-10 to max + 40C	Devices installed at distance min 10 cm all sides			
LED INDICATION RED	1 x blinking On 0,3 of 0,3 sec.	2 x blinking On 2 x0,3 of 1 sec.	3x blinking on 2x0,5 of 1 sec.	4x Blinking on 2x0,3 of 1 sec.	5x blinking on 2x0,3 of 1 sec.
RED	Temp. to high	Grid not available	Grid low	Grid high	Grid frequentie to high or to low
GREEN Blinking1-7x	Ready for start LED100% on	Power to the grid 1-7x= 0-200 Watt			

Loss of mains test			
Main voltage	110-240 V nom.	-20%	-20%
Switch-off time		< 0,1 sec.	< 0,1 sec.
Main frequency	60-50 Hz	+ 1%	- 1%
Result		No power to the grid	No power to the grid

Inverter	UWT-I-250	1,2 kg	H-195 mm D - 80 mm	W-140 mm
----------	-----------	--------	-----------------------	----------

5.4 Cleaning.

Clean the fan of the inverter and the top of all. The installed devices regularly so the air can flow easily through the inverter and Dumpload and besides the other installed devices so they can cool down. When you do not clean regularly the system, warranty will expire.

Power consumption of Extention-kit.

This UWT-I-250 inverter is special designed with a low power consumption of +/-0,2 W.

I hope that everything is clear for you after reading this manual. When you have questions you can contact your local dealer.